

Pressure Sensing Valve

Model 1672

Overview

AMOT Model 1672 Pressure Sensing Valves are 2-Way normally open sensors (closed under satisfied operation conditions) which are opened by the sensed pressure decreasing or increasing past the trip point. Dual purpose construction (trip on rising or falling pressure) provides a wide range of applications and permits easy field adjustment or changeover from trip on falling pressure to trip on rising pressure. The valve is snap-acting and suitable for hydraulic or gas control systems which up to 5.5 bar (80 psi) maximum control pressure.

Typical applications

- Engines
- Lubricating oil
- Cooling water
- Combustion air
- Control air
- Fuel oil
- Fuel gas

Key features and benefits

- Easy field adjustment
- Compatible in hydraulic or gas systems
- Factory set
- Gulpproofed finish and Viton seals
- Pneumatic lockout available
- Diaphragm sensor for pressure ranges from 0.3 - 21.7 bar (5 - 315 psi)
- Piston sensor for pressure ranges from 1 - 248 bar (15 - 3600 psi)
- Works in conjunction with other AMOT devices



**Model 1672
Pressure Sensing Valve**



Pressure Sensing Valve - Model 1672

Operation

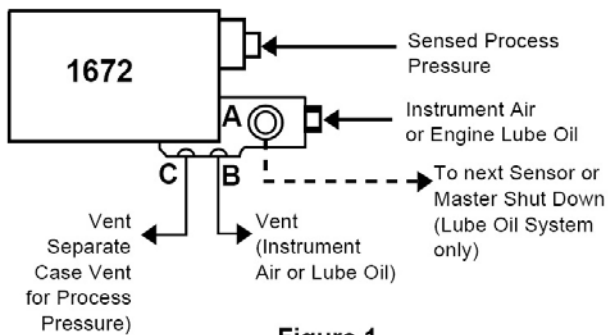

Figure 1

The operation of the 1672 Pressure Sensing Valve is simple and straightforward. Pressure ranges 1, 2 and 3 use a diaphragm sensor, and pressure ranges 4, 5, 6 and 7 use a piston sensor. The sensed pressure moves the diaphragm or piston operator against the larger adjusting spring. The motion is transmitted to the valve through a lever and fulcrum pin which operates the valve pushrod. Location of the pin in one of two holes in the case determines the rising or falling pressure trip function. See Parts List and cutaway view on page 6 and Figure 1 on left.

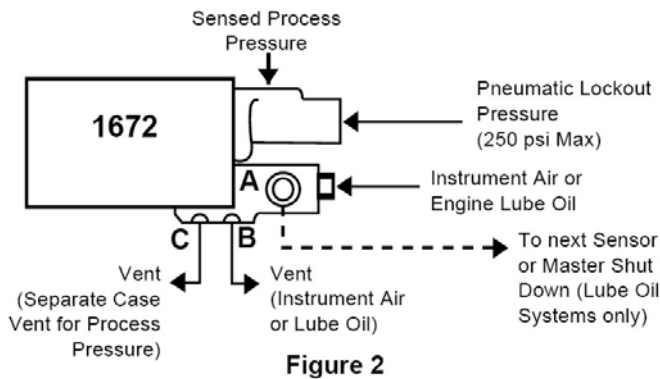

Figure 2

Pneumatic lock out is an optional feature which can eliminate the need for a separate blocking valve. For a tripping pressure of 1.1 bar (16 psi) falling, a 6.9 bar (100 psi) lockout pressure is required. For a tripping pressure of 2.1 bar (30 psi) falling, a 13.8 bar (200 psi) lockout pressure is required. The maximum lockout pressure is 17.2 bar (250 psi). This feature is only available on models in pressure range 1. See Figure 2 on left.

Adjustment (refer to cutaway view on page 6)

The trip-point setting is changed by turning adjustment nut (4) clockwise to raise the trip pressure on either a rising or falling pressure setting.

however, require minor adjustment when the trip action is changed from rising to falling if the valve leaks slightly with full pressure at the sensing port.

The small screw (25) which operates the valve pushrod is for factory adjustment and is not to be used to change the trippoint setting. It may,

Installation factors

For easy mounting two 3/8" – 16 NC tapped holes run through the back of the valve's case. Bolts can be threaded into the case from the back or 1/4" bolts can be installed from the valve's inside and threaded into a mounting plate behind the valve.

to prevent dirt from entering Ports B & C when they are not pointed downward. The valve should not be supported by piping unless it is secured against vibration.

Normally, the unit is installed with the vent connection (C) on the bottom however, it will operation in any position. Care should be taken

Pressure Sensing Valve - Model 1672

Specification

Housing	Cast aluminum		
Coating	Gulfproofed		
Internal parts	Aluminum and plated steel		
Control valve	Aluminum and stainless steel		
Standard valve seat & O-ring seal	Viton		
Standard diaphragm (ranges 1 - 3)	Buna N (Nitrile)		
Piston & Cylinder (ranges 4 - 7)	Stainless steel		
Piston seal (ranges 4 -7)	Teflon		
Flow coefficient	Cv = 0.3	Kv = 0.26	
Maximum valve operating pressure	5.5 bar	(80 psi)	
Net weight for:	Ranges 1 -3	2.0 kg	(4.5 lbs)
	Range 1 with lockout	2.5 kg	(5.5 lbs)
	Ranges 4 - 7	2.3 kg	(5.0 lbs)

Connections

All valve connections are made with ¼" pipe thread fittings. Apply a quality thread sealant such as Locktite™ Pipe Sealant to pipe thread connections. This sealant must NOT enter the valve passages. Teflon thread sealing tape may be used but must be applied such that shreds of the tape do not enter the valve. The minimum tubing size recommendation for air or gas is ¼" OD, and the minimum for short lengths of lube oil (especially in cold weather operation) is 5/16" OD. Be sure that all scale, dirt, tubing chips etc are removed from fittings and tubing before they are connected to the valve.

Important: The 1672 Pressure sensing Valve has an auxiliary inlet port (A) cast into the housing. The connection must be used on lube oil pressured systems. Do not connect the inlet port to the end of a branch run or tubing off a main header, as the falling pressure signal will not be properly transmitted to the Master Safety Control. When using the valve on a gas pressured system, the valve outlet (B) should

be connected to an outside vent line of large capacity, in such an application, the valve outlet (B) should be run to a vent line separate from the case vent (C) to prevent mixing potentially volatile fluids.

When sensing diesel fuel or other fluids that transmit medium to high frequency pulsations to the 1672 diaphragm, an AMOT 2185L001 or equal orifice should be ordered and installed at the diaphragm bonnet.

When checking an oil pressured system, be sure all trapped air is bled from the connection tubing. To do this, start at the first connection after the restriction orifice, and bleed each one until all air is purged. The most critical point is at the master safety control.

Pressure Sensing Valve - Model 1672

Dimensions

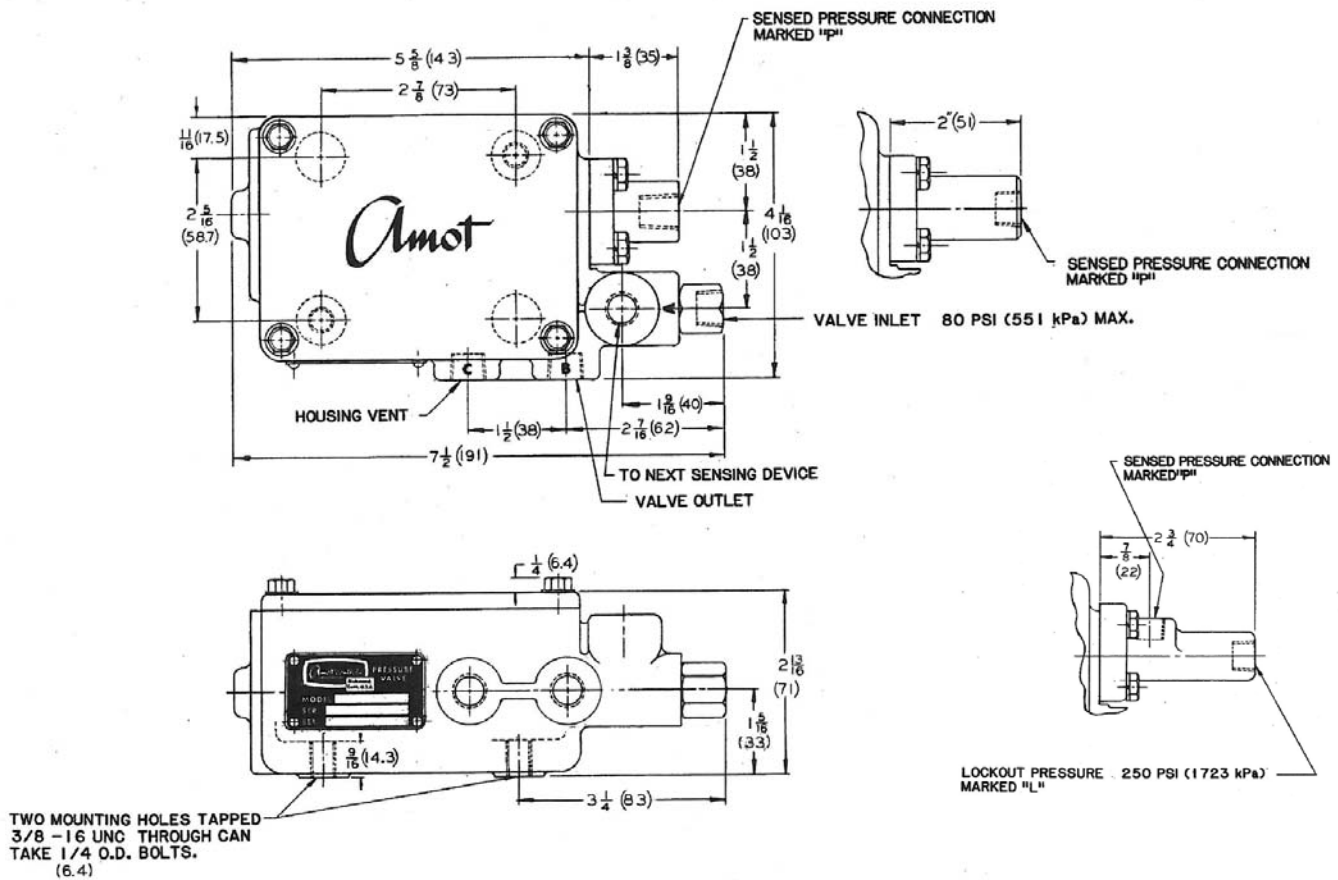

Differential

	Differential bar (psi)	Proof bar (psi)
Range 1	0.2-0.3 (3-5)	24 (350)
Range 2	0.3-0.7 (5-10)	24 (350)
Range 3	0.7-1.0 (10-15)	24 (350)
Range 4	0.7-1.8 (10-27)	69 (1000)
Range 5	0.6-2.7 (8-40)	69 (1000)
Range 6	2.1-4.1 (30-60)	276 (4000)
Range 7	2.1-9.7 (30-140)	276 (4000)

Differential is the change in sensed pressure above or below the trip point that is required to open the valve and cause an AMOT Pneumatic Indicating Relay to change from red to green with a 3.4 bar (50 psi) air pressure supply. The lower differential pressures shown are at the low end of the ranges and the higher pressures are for the higher end of the ranges.

Pressure Sensing Valve - Model 1672

How to order

Use the table below to select the unique specification of your 1672 Pressure Sensing Valve

1672E

Basic model number

1

F

1

- (AA)

(-AA) = Standard
(MTO) = Special requirements
Made to order

<u>Sensed Pressure Ranges</u>				Table A	Table B		Table C	
				Spring Code	Thread, Finish and Seal Code		Process Sensing Seal Code	
					Gulfproof Finish, Viton Seals NPT	Gulfproof Finish, Viton Seals, (BSP) (PL)*	Buna N	Viton
bar	(psi)	trip						
Range 1	0.56 - 2.27 0.35 - 2.06	(8 - 33) (5 - 30)	rising falling	1	F	M	1	4
Range 1 with pneumatic lockout	0.56 - 2.27 0.35 - 2.06	(8 - 33) (5 - 30)	rising falling	1	H	S	7	8
Range 2	1.73 - 11.03 1.38 - 10.34	(25 - 160) (20 - 150)	rising falling	2	F	M	1	4
Range 3	4.14 - 21.71 3.45 - 20.68	(60 - 315) (50 - 300)	rising falling	3	F	M	1	4
Range 4	2.42 - 17.23 1.04 - 15.85	(35 - 250) (15 - 230)	rising falling	2	E			3
Range 5	6.21 - 44.18 3.45 - 38.61	(90 - 650) (50 - 560)	rising falling	3	E			3
Range 6	14.48 - 96.52 12.07 - 86.18	(210 - 1400) (175 - 1250)	rising falling	2	C			3
Range 7	24.14 - 248.21 17.24 - 227.52	(350 - 3600) (250 - 3300)	rising falling	3	C			3

* Available in UK only

When ordering please specify the following:

- Basic model number
- Tripping pressure
- Tripping action:
 - to trip on rising pressure
 - to trip on falling pressure
- Pressure range from model code Table A. If this number is not specified, a unit in which the specified pressure falls nearest the middle of the range will be furnished.
- Thread Finish and Seal code selection Table B.
- Process Sensing Seal Material code from Table C.
- Finally, any of the following special features if required:
 - Pneumatic lock out (available on Range 1 only)
 - BSP Parallel Port Threads (instead of NPT)

The unit may be ordered using the full description as shown above or by constructing a model number using the table. The complete model number for a unit with Range 1, gulfproofed, NPT threads, Buna N seals and a 20 psi falling pressure setting is "1672E1F1 **set at 20 psi falling**".

Pressure settings are not part of this model code. The desired setting and whether it is trip on rising or falling pressure must be specified separately and will appear on the nameplate.

Note: Letters or numbers in the MTO space other than nothing, A1 or AA, indicate the unit is built to special requirements and some of the other code numbers may not be valid. Check with the AMOT for full specification of such models.

Pressure Sensing Valve - Model 1672

Maintenance

Properly applied and installed, Model 1672 series valves require minimal maintenance. An inspection of the unit at yearly intervals is adequate to detect and make provision for normal wear. The diaphragm seals and o-rings should be checked for wear, damage, and hazardous seals and o-rings with Dow Corning no. 33 Grease (AMOT part number 911L001) before installing them. Other internal parts should be inspected for excessive wear or damage or replaced as necessary. Use caution on assembly of seal (ranges 4 - 7) so the edge is not damaged. Cycle the valve about 12 times before making the final trip setting.

It is recommended that the valve should be checked monthly for proper function by simulating an unsafe condition if possible.

AMOT designs and tests all its products to ensure that high quality standards are met. For good product life, carefully follow the installation and maintenance instruction; failure to do so could result in damage to the equipment being protected or controlled.

Service Kits

Ref no.	Qty	Description
for model 1672E-F1, M1 Service Kit 9118X		
14	1	Diaphragm - Buna N (Nitrile)
18	1	O-ring - Buna N (Nitrile)
20	1	Valve seat - Buna N (Nitrile)
51	1	Gasket
for model 1672E-F4, M4 Service Kit 9118X001		
14	1	Diaphragm - Viton
18	1	O-ring - Viton
20	1	Valve seat - Viton
51	1	Gasket
for model 1672E-H7, S7 Service Kit 9118X002		
--	1	Service kit no.: 9118X
45	2	O-ring - Buna N
for model 1672E-H8, S8 Service Kit 9118X003		
--	1	Service kit 9118X001
45	2	O-ring - Viton
for model 1672E-E3 Service Kit 9112X001		
18	1	O-ring - Viton
20	1	Valve Seat - Viton
32	1	Seal
51	1	Gasket
for model 1672E-C3, Service Kit 9119X001		
18	1	O-ring - Viton
20	1	Valve seat - Viton
32	1	Seal
51	1	Gasket

When contacting AMOT regarding operation of a control always give the model number if ordering service parts, also include the description, part number and quantity desired. If any parts are ordered by reference number only, please also include the datasheet number.

Cutaway View

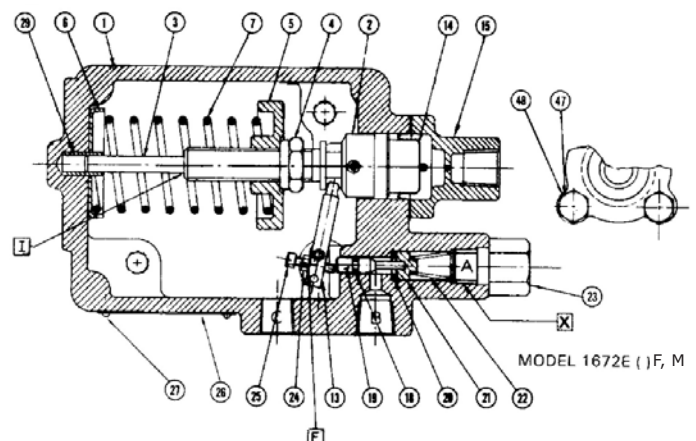

Americas

AMOT USA
8824 Fallbrook Dr
Houston
TX 77064
USA

Tel: +1 (281) 940 1800
Fax +1 (713) 559 9419
Email sales@amotusa.com

Asia and Australasia

AMOT Shanghai
Rm A308 Building A8
Jiahua Business Center
808 Hongqiao Road
Shanghai 200030
China

Tel +86 (0) 21 6447 9708
Fax +86 (0) 21 6447 9718
Email shanghai@amot.com

AMOT Singapore
10 Eunos Road 8 #12-06
Singapore Post Centre
Singapore 408600

Tel +65 6408 6265
Fax +65 6293 3307
Email singapore@amot.com

Europe and Africa

AMOT
Western Way
Bury St Edmunds
Suffolk, IP33 3SZ
England

Tel +44 (0) 1284 762222
Fax +44 (0) 1284 760256
Email info@amot.com

AMOT Controls GmbH
Rondenbarg 25
22525 Hamburg
Germany

Tel +49 (0) 40 8537 1298
Fax +49 (0) 40 8537 1331
Email germany@amot.com

AMOT Russia
#34 Shabolovka Street
Building 2
Moscow 115419
Russia

Tel: +7 495 617 12 93
Fax: +7 495 913 97 65